

# The Burgers Spacetime Dislocation Constant $b_0$ and the Derivation of Planck's Constant

Pierre A. Millette

PierreAMillette@alumni.uottawa.ca, Ottawa, Canada

In a previous paper, a framework for the physical description of physical processes at the quantum level based on dislocations in the spacetime continuum within STCED (Spacetime Continuum Elastodynamics) was proposed and it was postulated that the spacetime continuum has a granularity characterized by a length  $b_0$  corresponding to the smallest elementary Burgers dislocation vector possible. Based on the identification of screw dislocations in the spacetime continuum with photons, the relation between the Burgers constant  $b_0$  and Planck's constant  $h$  is determined. Planck's constant is expressed in terms of the spacetime continuum constants. The calculated value of  $b_0$  is found to be equivalent to the Planck length within the approximations of the derivation. Numerical values of the spacetime constants  $\bar{\kappa}_0$ ,  $\bar{\mu}_0$  and  $\bar{\rho}_0$  are derived. A consistent set of the spacetime constants is proposed based on the Burgers spacetime dislocation constant  $b_0$  being equivalent to the Planck length  $\ell_P$ .

## 1 Introduction

A previous paper [1] provided a framework for the physical description of physical processes at the quantum level based on dislocations in the spacetime continuum within the theory of the Elastodynamics of the Spacetime Continuum (STCED). Dislocations in the spacetime continuum represent the fundamental displacement processes that occur in its structure, corresponding to basic quantum phenomena and quantum physics in STCED.

Spacetime Continuum Elastodynamics (STCED) [2–5] is based on analyzing the spacetime continuum within a continuum mechanical and general relativistic framework. As shown in [2], for an isotropic and homogeneous spacetime continuum, the STC is characterized by the stress-strain relation

$$2\bar{\mu}_0\varepsilon^{\mu\nu} + \bar{\lambda}_0g^{\mu\nu}\varepsilon = T^{\mu\nu} \quad (1)$$

where  $T^{\mu\nu}$  is the energy-momentum stress tensor,  $\varepsilon^{\mu\nu}$  is the resulting strain tensor, and

$$\varepsilon = \varepsilon^\alpha_\alpha \quad (2)$$

is the trace of the strain tensor obtained by contraction.  $\bar{\lambda}_0$  and  $\bar{\mu}_0$  are the Lamé elastic constants of the spacetime continuum:  $\bar{\mu}_0$  is the shear modulus and  $\bar{\lambda}_0$  is expressed in terms of  $\bar{\kappa}_0$ , the bulk modulus:

$$\bar{\lambda}_0 = \bar{\kappa}_0 - \bar{\mu}_0/2 \quad (3)$$

in a four-dimensional continuum.

A dislocation is characterized by its dislocation vector, known as the *Burgers vector*,  $b^\mu$  in a four-dimensional continuum, defined positive in the direction of a vector  $\xi^\mu$  tangent to the dislocation line in the spacetime continuum [6, pp. 17–24].

As discussed in [1], the spacetime continuum, at the quantum level, is assumed to have a granularity characterized by

a length  $b_0$  corresponding to the smallest elementary Burgers dislocation vector possible in the STC. Then the magnitude of a Burgers vector can be expressed as a multiple of the elementary Burgers vector:

$$b = nb_0. \quad (4)$$

We find that  $b$  is often divided by  $2\pi$  in dislocation equations, and hence the constant

$$\bar{b} = \frac{b}{2\pi}, \quad (5)$$

is also defined.

In this paper, we explore the relation between the spacetime Burgers dislocation constant  $b_0$  and Planck's constant, and derive the value of the spacetime continuum constants.

## 2 Screw dislocations in quantum physics

There are two types of dislocations [1]: 1) Edge dislocations corresponding to dilatations, longitudinal displacements with an associated rest-mass energy, are identified with particles, and 2) screw dislocations corresponding to distortions, transverse displacements which are massless, are identified with photons. Arbitrary mixed dislocations can be decomposed into a screw component and an edge component, giving rise to wave-particle duality [5].

Hence screw dislocations in the spacetime continuum are massless, transverse deformations, and are identified specifically with photons. As shown in [1], the screw dislocation Burgers vector is equal to the wavelength of the screw dislocation

$$b = \lambda. \quad (6)$$

This result is illustrated in Fig. 1.

If we consider a stationary screw dislocation in the spacetime continuum, with cylindrical polar coordinates  $(r, \theta, z)$ ,

Fig. 1: A wavelength of a screw dislocation.

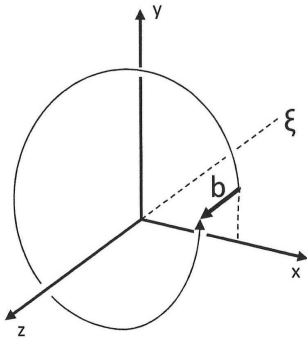

with the dislocation line along the  $z$ -axis (see Fig. 2), then the Burgers vector is along the  $z$ -axis and is given by  $b_r = b_\theta = 0$ ,  $b_z = b$ , the magnitude of the Burgers vector.

The only non-zero component of the deformation is given by [6, pp. 60–61]

$$u_z = \frac{b}{2\pi} \theta = \tilde{b} \tan^{-1} \frac{y}{x}. \tag{7}$$

Similarly, the only non-zero components of the stress and strain tensors are given by

$$\begin{aligned} \sigma_{\theta z} &= \frac{b}{2\pi} \frac{\bar{\mu}_0}{r} \\ \varepsilon_{\theta z} &= \frac{b}{4\pi} \frac{1}{r} \end{aligned} \tag{8}$$

respectively.

The strain energy density of the screw dislocation is given by the transverse distortion energy density [2, Eq. (74)]. The non-zero components of the strain tensor are as defined in (8). Hence

$$\mathcal{E}_\perp = \bar{\mu}_0 (\varepsilon_{\theta z}^2 + \varepsilon_{z\theta}^2). \tag{9}$$

Substituting from (8),

$$\mathcal{E}_\perp = \frac{\bar{\mu}_0 b^2}{8\pi^2} \frac{1}{r^2} = \mathcal{E}. \tag{10}$$

### 3 Planck's constant

Based on our identification of screw dislocations in the space-time continuum with photons, we can determine the relation between the Burgers constant  $b_0$  and Planck's constant  $h$ .

Even though the photon is massless, its energy is given by the strain energy density of the screw dislocation, equivalent to the transverse distortion energy density. As shown in [2, Eq. (147)],

$$\hat{p}^2 c^2 = 32\bar{\kappa}_0 \mathcal{E}_\perp, \tag{11}$$

where  $\hat{p}$  is the momentum density. For a screw dislocation, substituting for  $\mathcal{E}_\perp$  from (10) in (11), we obtain

$$\hat{p}^2 c^2 = 32\bar{\kappa}_0 \frac{\bar{\mu}_0 b^2}{8\pi^2} \frac{1}{r^2}. \tag{12}$$

The kinetic energy density  $\hat{p}c$  has to be equivalent to the wave energy density  $\widehat{h\nu}$  for the screw dislocation (photon):

$$\hat{p}c = \widehat{h\nu}. \tag{13}$$

The photon's energy is given by

$$h\nu = \int_V \widehat{h\nu} dV = \widehat{h\nu} V \tag{14}$$

where  $V$  is the volume of the screw dislocation. We consider the smallest Burgers dislocation vector possible and replace  $b$  with the elementary Burgers dislocation vector  $b_0$  and  $V$  with the smallest volume  $V_0$  to derive Planck's constant. Combining (14), (13) and (12), (14) becomes

$$h = \sqrt{\frac{16\bar{\kappa}_0 \bar{\mu}_0 b_0^2}{(2\pi r)^2} \frac{V_0}{\nu}}. \tag{15}$$

Using (6), the frequency  $\nu = c/\lambda$  becomes  $\nu = c/b_0$  for the smallest Burgers dislocation vector considered. Substituting into (15), the equation becomes

$$h = \frac{4\sqrt{\bar{\kappa}_0 \bar{\mu}_0} b_0}{2\pi r} \frac{V_0 b_0}{c}. \tag{16}$$

The volume of one wavelength of the screw dislocation can be approximated by a cylinder and, using (6), written as

$$V = \pi r^2 \lambda = \pi r^2 b, \tag{17}$$

which in the limit as  $b \rightarrow b_0$ , becomes

$$V_0 = \pi r^2 b_0. \tag{18}$$

Substituting for  $V_0$  into (16), the equation becomes

$$h = \frac{4\sqrt{\bar{\kappa}_0 \bar{\mu}_0} b_0}{2\pi r} \frac{\pi r^2 b_0^2}{c}. \tag{19}$$

Fig. 2: A stationary screw dislocation in cylindrical polar coordinates  $(r, \theta, z)$  [6, p. 60].

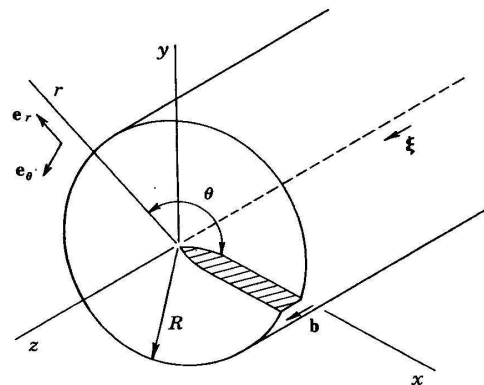

Simplifying,

$$h = \frac{2\sqrt{\bar{\kappa}_0\bar{\mu}_0}}{c}rb_0^3, \quad (20)$$

and in the limit as  $r$  approaches  $b_0$ , becomes

$$h = 2\frac{\sqrt{\bar{\kappa}_0\bar{\mu}_0}b_0^4}{c} \quad (21)$$

where the units of  $h$  are J-s as expected. This is the basic definition of Planck's constant  $h$  in terms of the Lamé spacetime constants and the Burgers spacetime dislocation constant  $b_0$ .

This relation can be further simplified using  $\bar{\mu}_0 = 32\bar{\kappa}_0$  from [2, Eq. (150)]. Then

$$h = 8\sqrt{2}\frac{\bar{\kappa}_0b_0^4}{c} = \frac{1}{2\sqrt{2}}\frac{\bar{\mu}_0b_0^4}{c}. \quad (22)$$

Numerically,

$$\bar{\mu}_0b_0^4 = 2\sqrt{2}hc = 5.8 \times 10^{-25} \text{ J m}. \quad (23)$$

The value of the spacetime shear modulus  $\bar{\mu}_0$  is not a known physical constant, neither is the value of the spacetime bulk modulus  $\bar{\kappa}_0$ . However, Macken [8] has derived a value of  $\bar{\kappa}_0 = 4.6 \times 10^{113} \text{ J/m}^3$  which as we will see in Section 4 is expected to be a valid estimate. Using  $\bar{\mu}_0 = 32\bar{\kappa}_0$  from Millette [2, Eq. (150)], this yields a value of

$$\bar{\mu}_0 = 1.5 \times 10^{115} \text{ J/m}^3. \quad (24)$$

Note that the units can be expressed equivalently as  $\text{N/m}^2$  or  $\text{J/m}^3$ . Substituting for  $\bar{\mu}_0$  in (23), we obtain the value of the elementary Burgers vector

$$b_0 = 1.4 \times 10^{-35} \text{ m}. \quad (25)$$

This value compares very favorably with the Planck length  $1.6 \times 10^{-35} \text{ m}$ . Given the approximations used in its derivation, this suggests that the elementary Burgers vector  $b_0$  and the Planck length are equivalent.

With these constants, we are now in a position to calculate the remaining unknown spacetime constant, the density of the spacetime continuum  $\bar{\rho}_0$ . Using the relation [2]

$$c = \sqrt{\frac{\bar{\mu}_0}{\bar{\rho}_0}}, \quad (26)$$

the density of the spacetime continuum is

$$\bar{\rho}_0 = 1.7 \times 10^{98} \text{ kg/m}^3. \quad (27)$$

#### 4 Analytic form of constants $b_0$ and $\bar{\kappa}_0$

Blair [7, p. 3–4] writes Einstein's field equation as

$$\mathbf{T} = \frac{c^4}{8\pi G}\mathbf{G},$$

where  $\mathbf{T}$  is the stress energy tensor,  $\mathbf{G}$  is the Einstein curvature tensor and  $G$  is the universal gravitational constant. He notes the very large value of the proportionality constant. This leads him to point out that spacetime is an elastic medium that can support waves, but its extremely high stiffness means that extremely small amplitude waves have a very high energy density. He notes that the coupling constant  $c^4/8\pi G$  can be considered as a modulus of elasticity for spacetime, and identifies the quantity  $c^3/G$  with the characteristic impedance of spacetime [7, p. 45].

From this, Macken [8] derives an “interactive bulk modulus of spacetime”, which we identify with the spacetime continuum bulk modulus, given by

$$\bar{\kappa}_0 = \frac{c^7}{\hbar G^2}. \quad (28)$$

The result obtained for the numerical value of  $b_0$  and its close correspondance to the Planck length suggests that the value of  $\bar{\kappa}_0$  proposed in [8] is correct. From Millette [2, Eq. (150)] we then have

$$\bar{\mu}_0 = 32\frac{c^7}{\hbar G^2}. \quad (29)$$

From (23), we can write

$$b_0^4 = 2\sqrt{2}\frac{hc}{\bar{\mu}_0}. \quad (30)$$

Substituting from (29), this relation becomes

$$b_0^4 = \frac{\sqrt{2}\pi}{8}\frac{\hbar^2 G^2}{c^6} \quad (31)$$

and finally

$$b_0 = \left(\frac{\pi}{4\sqrt{2}}\right)^{\frac{1}{4}}\sqrt{\frac{\hbar G}{c^3}} = 0.86\ell_P \quad (32)$$

where  $\ell_P$  is Planck's length, defined as [9]

$$\ell_P = \sqrt{\frac{\hbar G}{c^3}}. \quad (33)$$

Hence, as mentioned in Section 3, this suggests that the elementary Burgers dislocation vector  $b_0$  and the Planck length  $\ell_P$  are equivalent within the approximations of the derivation.

#### 5 Recommended constants

Starting from the statement that the Burgers spacetime dislocation constant  $b_0$  is equivalent to the Planck length  $\ell_P$ , we derive the constant of proportionality of (21). We thus set

$$h = k\frac{\sqrt{\bar{\kappa}_0\bar{\mu}_0}b_0^4}{c} \quad (34)$$

where  $k$  is the improved constant of proportionality for the relation. Substituting for  $\bar{\kappa}_0$  from (28), for  $\bar{\mu}_0$  from (29), and setting  $b_0 = \ell_P$  from (33), the equation becomes

$$h = k \sqrt{32} \frac{c^7}{\hbar G^2} \frac{1}{c} \frac{\hbar^2 G^2}{c^6} \quad (35)$$

from which we obtain

$$k = \frac{\pi}{2\sqrt{2}}. \quad (36)$$

Hence, with the Burgers spacetime dislocation constant  $b_0$  equivalent to the Planck length  $\ell_P$ , the basic definition of Planck's constant  $h$  in terms of the Lamé spacetime constants and the Burgers spacetime dislocation constant  $b_0$  is given by

$$h = \frac{\pi}{2\sqrt{2}} \frac{\sqrt{\bar{\kappa}_0 \bar{\mu}_0} b_0^4}{c}. \quad (37)$$

In terms of  $\bar{\kappa}_0$ , we have

$$h = 2\pi \frac{\bar{\kappa}_0 b_0^4}{c} \quad (38)$$

or

$$\bar{\hbar} = \frac{\bar{\kappa}_0 b_0^4}{c} \quad (39)$$

and in terms of  $\bar{\mu}_0$ , we have

$$h = \frac{\pi}{16} \frac{\bar{\mu}_0 b_0^4}{c}. \quad (40)$$

As stated, the Burgers spacetime dislocation constant  $b_0$  is given by

$$b_0 = \ell_P = \sqrt{\frac{\hbar G}{c^3}} \quad (41)$$

and the spacetime continuum Lamé constants are as per (28) and (29):

$$\begin{aligned} \bar{\kappa}_0 &= \frac{c^7}{\hbar G^2} \\ \bar{\mu}_0 &= 32 \frac{c^7}{\hbar G^2}. \end{aligned} \quad (42)$$

It is recommended that the relations in this section be retained as the official definition of these constants.

## 6 Discussion and conclusion

We have expressed Planck's constant in terms of the spacetime continuum constants  $\bar{\kappa}_0$ ,  $\bar{\mu}_0$ ,  $b_0$ , and the speed of light  $c$ . The calculated value of  $b_0$  compares very favorably with the Planck length and suggests that the elementary Burgers vector  $b_0$  and the Planck length are equivalent within the approximations of the derivation. An estimate of the numerical values of the spacetime constants  $\bar{\kappa}_0$ ,  $\bar{\mu}_0$  and  $\bar{\rho}_0$  is also obtained, based on Macken's [8] derived value of  $\bar{\kappa}_0$  which is

found to be a valid estimate, given the agreement between  $b_0$  and the Planck length  $\ell_P$ .

A consistent set of recommended spacetime constants is obtained based on setting the Burgers spacetime dislocation constant  $b_0$  equivalent to the Planck length  $\ell_P$ .

Submitted on July 15, 2015 / Accepted on July 18, 2015

## References

1. Millette P.A. Dislocations in the Spacetime Continuum: Framework for Quantum Physics. *Progress in Physics*, 2015, v. 11 (4), 287–307.
2. Millette P.A. Elastodynamics of the Spacetime Continuum. *The Abraham Zelmanov Journal*, 2012, v. 5, 221–277.
3. Millette P.A. The Elastodynamics of the Spacetime Continuum as a Framework for Strained Spacetime. *Progress in Physics*, 2013, v. 9 (1), 55–59.
4. Millette P.A. Strain Energy Density in the Elastodynamics of the Spacetime Continuum and the Electromagnetic Field. *Progress in Physics*, 2013, v. 9 (2), 82–86.
5. Millette P.A. Wave-Particle Duality in the Elastodynamics of the Spacetime Continuum (STCED). *Progress in Physics*, 2014, v. 10 (4), 255–258.
6. Hirth R.M. and Lothe J. Theory of Dislocations, 2<sup>nd</sup> ed. Krieger Publishing Co., Florida, 1982.
7. Blair D.G., ed. The Detection of Gravitational Waves. Cambridge University Press, Cambridge, 1991.
8. Macken J.A. The Universe is Only Spacetime, Rev. 7.1. Self-published, Santa Rosa, CA, 2013, p. 4-24.
9. Kaku M. Quantum Field Theory, A Modern Introduction. Oxford University Press, Oxford, 1993, p. 10.